



REX POWER MAGNETICS

A DIVISION OF TRANSFACTOR INDUSTRIES INC.
 65 BASALTIC RD, CONCORD, ON, CA L4K 1G4
 TEL: 905-695-8844 • FAX: 905-695-8855
 WWW.REXPOWERMAGNETICS.COM

TRANSFORMER SPECIFICATION

- 3 Phase Isolation
- Dry Type
- ANN Self Cooled

Purchaser: TBA
 PO#: TBA
 SWO#: TBA
 Qty: TBA

Coils: Copper
 Cat. No.: BC9H-M
 kVA: 9
 Primary: 480 Delta Volts
 Secondary: 208 Y/120 Volts
 Primary Taps: 5 %
 -Taps FCAN 1
 -Taps FCBN 1
 Frequency: 60 Hz
 Sound Level: 45 dB Max.
 BIL: 10 kV
 Insulation Class: 220° C
 Temperature Rise: 150° C
 Impedance: 6.5 - 7.5 %
 Weight: 143 Lbs

Termination	Location	Terminals
Primary:	Front	Terminal Blocks
Secondary:	Front	Terminal Blocks

Wiring Connection:

Primary:	H1-H2-H3	Voltage	% Tap	Jumpers To:
504	105.0			1-1-1
480	100.0			2-2-2
456	95.0			3-3-3

Secondary:	X0-X1-X2-X3	Phase	Connect Loads To:
208	3		X1-X2-X3
120	1		X0-X1, X0-X2, and/or X0-X3

Preliminary Drawing ONLY

This drawing may NOT truly reflect our final design.
 Any resulting order(s) must be accompanied by or
 refer to this drawing and be marked with any
 proposed changes

Standards:

1. CSA Certified
 - File No. LR34493
2. UL Listed
 - File No. E108255

Standard Features:

1. Anti-vibration pads installed between the enclosure base and the core & coil assembly
2. Ground lug provided

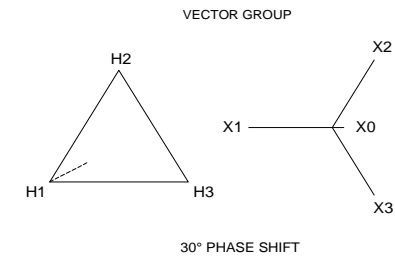

CSA Enclosure:

1. Type 3R (NEMA 3R)
 - Sprinklerproof when the angle between sprinkler heads and opening in the enclosure does not exceed 45 degree from the vertical.
2. Ventilated
3. ASA 61 grey
4. Floor/Wall mounting

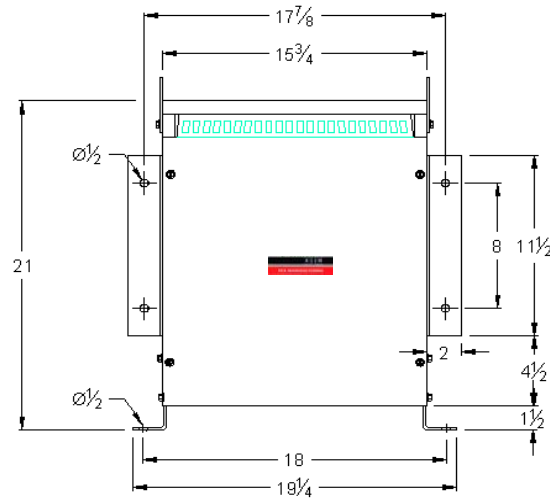

FRONT VIEW

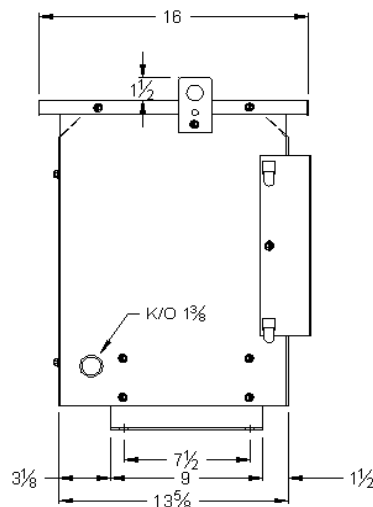

SIDE VIEW

2	Updated Logo & Enclosure Dimension	AP	VS	Mar.26, 2012
1	Updated Standard Features	SA	VS	Oct. 26, 2010
REV#	Remarks	BY	Approved By	DATE

Prepared by: SA
 Approved by: VS
 Date: OCT 26 2010