



REX POWER MAGNETICS

DIVISION OF TRANSFACTOR INDUSTRIES INC.
65 Basaltic Rd. Concord, ON, L4K 1G4 Canada
Tel: 905-695-8844, 1-800-387-2840 Fax: 905-695-8855
www.RexPowerMagnetics.com

ENERGY EFFICIENT TRANSFORMER

- 3 Phase Isolation
- Dry Type
- ANN Self Cooled

Purchaser: TBA
 PO#: TBA
 SWO#: TBA
 Qty: TBA

Coils: Copper Wound
 Cat. No.: BC15J-M/E3R/Z

kVA: 15
 Primary: 600 Delta Volt
 Secondary: 208 Y/120 Volt

Primary Taps: 2.5 %
 -Taps FCAN 2
 -Taps FCBN 2

Frequency: 60 Hz
 Sound Level: 45 dB Max.

Insulation Class: 220° C
 Temperature Rise: 150° C

BIL: 10 kV

Min. Efficiency: 97.0 %
 - Calculated @ 35% Loaded

Impedance: 5.0 - 6.0 %
 Weight: 235 Lbs

Termination	Location	Lug Size
Primary:	Front	2-14 AWG
Secondary:	Front	2-14 AWG

Wiring Connection:

Primary Voltage	H1-H2-H3 % Tap	Jumpers To:
630	105.0	1-1-1
615	102.5	2-2-2
600	100.0	3-3-3
585	97.5	4-4-4
570	95.0	5-5-5

Secondary Voltage	X0-X1-X2-X3 Phase	Connect Loads To:
208	3	X1-X2-X3
120	1	X0-X1, X0-X2, and/or X0-X3

PRELIMINARY DRAWING ONLY
 This drawing may NOT truly reflect our Final Design. Any resulting order(s) must be accompanied by, or refer to this drawing and be marked with any proposed changes.

Standards:

1. CSA Certified
- File No. LR34493
2. UL Listed
- File No. E108255

Standard Features:

1. Anti-vibration pads installed between the enclosure base and the core & coil assembly
2. Ground lug provided

Special Features:

1. Transformer meets Efficiency per CSA C802.2-06
2. Transformer meets NEMA TP-1-2002 Efficiency

Vector Group

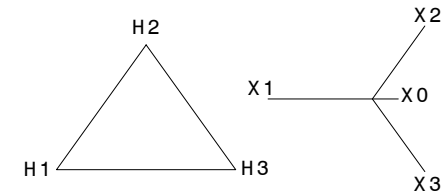

30° Phase Shift

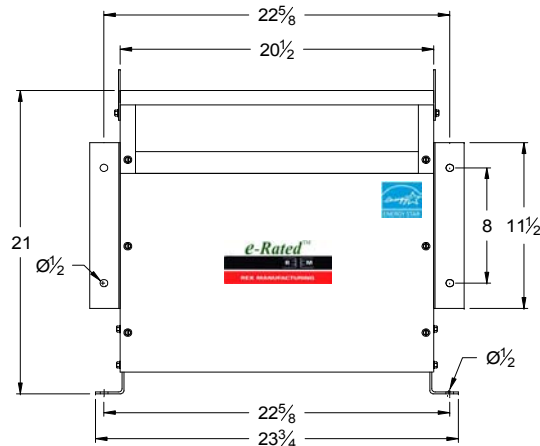

FRONT VIEW

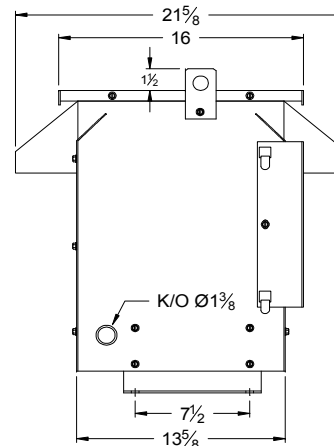

SIDE VIEW

CSA Enclosure:

- Type 3R (NEMA 3R)
- Indoor/Outdoor Ventilated
- ASA 61 Grey
- Floor Mounting

Prepared by: AP
 Approved by: VS
 Date: DEC.4, 2008