



REX POWER MAGNETICS

DIVISION OF TRANSFACTOR INDUSTRIES INC.  
65 Basaltic Rd. Concord, ON, L4K 1G4 Canada  
Tel: 905-695-8844, 1-800-387-2840 Fax: 905-695-8855  
www.RexPowerMagnetics.com

### TRANSFORMER SPECIFICATION

- 3 Phase Auto
- Dry Type
- ANN -Self cooled

Purchaser: TBA  
 PO#: TBA  
 SWO#: TBA  
 Qty: TBA

**PRELIMINARY DRAWING ONLY**  
 This drawing may NOT truly reflect our Final Design. Any resulting order(s) must be accompanied by, or refer to this drawing and be marked with any proposed changes.

Coils: Copper Wound  
 Cat. No.: RC9H-B  
 kVA: 9  
 Primary: 480 Volts  
 Secondary: 208 Volts  
 Frequency: 60 Hz  
 Insulation Class: 220° C  
 Temperature Rise: 150° C  
 Impedance: 4.0 - 5.0 %  
 Weight: 110 Lbs

Termination	Location	Terminals
Primary:	Front	Screws
Secondary:	Front	Screws

#### Wiring Connection:

**Primary:**  
 Voltage 480  
 Connect Lines To: H1-H2-H3

**Secondary:**  
 Voltage 208  
 Connect Loads To: X1-X2-X3

#### Standards:

1. CSA Certified  
 - File No. LR34493
2. UL Listed  
 - File No. E108255

#### Standard Features:

1. Anti-Vibration pads installed between the enclosure base and the core & coil assembly
2. Ground lug provided

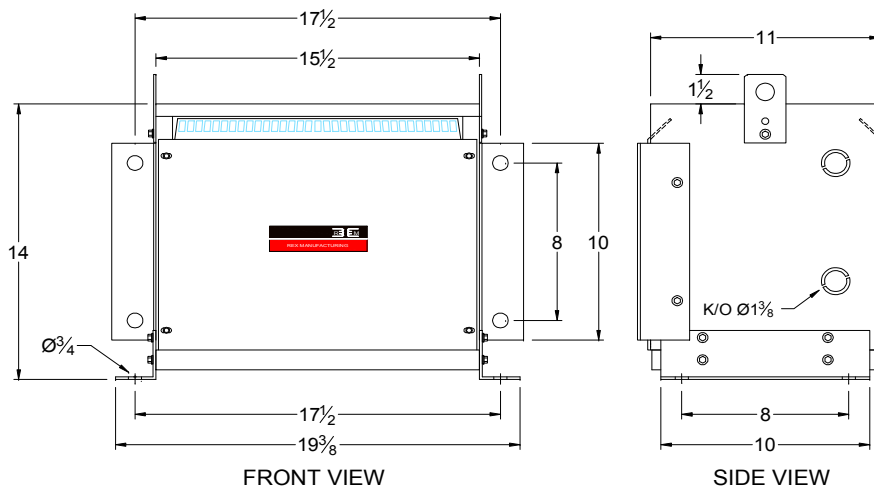
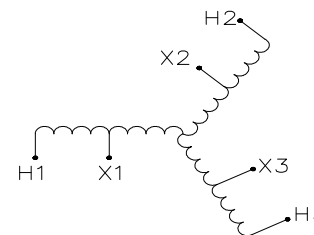

#### CSA Enclosure:

- Type 1 (NEMA 1)
- Indoor Ventilated
- ASA 61 Grey
- Floor/Wall Mounting

Prepared by: AP  
 Approved by: VS  
 Date: DEC.4, 2008